

# Data Loggers

Product	Description	Supported Controllers	Operating Requirements	Page
<b>D4T 1/4 DIN Data Logger</b>	1 to 24 channels 4.3 in. touch screen with data encrypted files and trend chart graphs	D4T and Flex Modules (FM)	None	<b>353</b>
<b>F4T With INTUITION®</b>	1 to 24 channels 4.3 in. touch screen with data encrypted files and trend chart graphs	F4T and Flex Modules (FM)	None	<b>358</b>
<b>EZ-ZONE® RM System with Access Module</b>	Communications module with data logging ability	EZ-ZONE RM	None	<b>359</b>
<b>RMA PLUS Remote Access Module</b>	Communications module with data logging ability	EZ-ZONE RM, PM, EZK, ST, PM PLUS and POWERGLIDE™	None	<b>360</b>
<b>SpecView HMI Software</b>	Human machine interface for Watlow controllers	See catalog page <b>362</b>	Windows® 10, 8.1, 8, 7, Vista, Server 2003, XP (Home and Professional), 2000, NT 4.0, ME, 98 and 95	<b>361</b>
<b>Silver Series EM</b>	Rugged, touch screen operator interface terminal	EZ-ZONE and many others	EZwarePlus: Windows® 10, 8.1, 8, 7, Vista and XP	<b>366</b>





# Data Loggers

## D4T 1/4 DIN Data Logger

The D4T with INTUITION® data logger offers a wide range of field removable I/O modules for maximum design flexibility. Configurations can be custom tailored to meet the scaling needs of a tremendous range of equipment and applications while providing exactly the hardware types required for compatibility. The D4T data logger also features a 4.3 inch, color, graphical touch panel. Combining power, flexibility and functionality, this new data logger offers unmatched versatility, and its best-in-class ease of use could very well make user manuals a thing of the past.

### Features and Benefits

#### 4.3-inch, color touch panel with high-resolution, graphical user-interface

- Shortens learning curve and reduces operator errors
- Allows channels, alarms, inputs and outputs to be personalized with user defined names
- Intuitive screens layout and menu navigation
- Programmable to show information in multiple languages

#### Data logging

- Easily complies with regulatory standards with ability to choose encrypted, .CSV or both types of file formats for tamper proof record needs
- Enables security using lock-out security levels for different user groups
- Simplifies record keeping management with ability to archive records to the cloud or a connected PC network
- Flexibility to select which parameters to log from one to up to 128 points simultaneously
- Choose where you want to store the files—inside the controller, on a connected USB memory device, or to a connected PC anywhere in the world
- Record as fast as one time per 0.1 second or as slow as one time per hour

#### 1 to 24 channel data logger

- Scalable channels, pay for only what you need
- Compatible with temperature, altitude, humidity, ac current and other 0-10VDC or 0-20mA process units
- Flexibility to meet diverse process applications
- Field expandable channels and I/O if application needs grow in the future



#### Batch processing with bar code data entry

- Easily collects and manages data records
- Inputs information from bar code scan for fast and easy data entry
- Provides data security through password and data log encrypted file options
- Improves manufacturing robustness via reminder screens ensuring all data is entered during processing
- Helps ensure compliance with growing regulations and minimizes warranty exposure
- Eliminates part processing skips or walk arounds due to improved quality control
- Produces formatted data record report for easy receipt or record management uses

#### Trend Screens

- Create up to four unique trend graph screens
- Graph any input sensor or process value

#### COMPOSER® graphical configuration PC software

- Speeds up and simplifies commissioning
- Archives and documents controller setup
- Connects with controller easily via Ethernet

#### Many communications options available including Ethernet Modbus® TCP and SCPI and EIA-232/485 Modbus® RTU

- Offers two USB host ports and one device port
- Simplifies methods to manually or automatically archive data log files to cloud or PC
- Easily connect and transfer data log or configuration set up files

## D4T 1/4 DIN Data Logger

### Features and Benefits (con't)

#### Modular design

- Adapts quickly to evolving requirements
- Offers numerous types of field pluggable modules for maximum flexibility and easiest compatibility
- Features scalable and modular firmware functions
- Delivers scalable input/output quantities from 1 to 24

#### Agency certifications include UL®, FM, CE, RoHS, W.E.E.E., NEMA 4X/IP65

- Ensures high quality and reliability
- Verifies performance in installations worldwide

#### Off-the-shelf solution

- Provides cost-effective “make versus buy”
- Offers preconfigured touch-panel screens
- Assures quicker time to market

### Key Features and Options

- Ethernet Modbus® TCP connectivity
- Multiple high-speed USB host ports
- Universal, thermistor and ac current measurement inputs
- Inputs and outputs expandable from 1 to 24
- Programmable timers, counters, math and logic
- Temperature, altitude, relative humidity and Vaisala® humidity compensation
- USB configuration port
- Configuration settings can be stored and recalled
- Removable modules and connectors
- Front-panel mount and flush mounting options
- Right angle and front-screw terminal options
- UL® listed, CSA, CE, RoHS, W.E.E.E., FM

### Common Specifications

#### Line Voltage/Power

- Data retention upon power failure via nonvolatile memory

#### Functional Operating Range

- Type J: -346 to 2192°F (-210 to 1200°C)
- Type K: -454 to 2500°F (-270 to 1371°C)
- Type T: -454 to 750°F (-270 to 400°C)
- Type E: -454 to 1832°F (-270 to 1000°C)
- Type N: -454 to 2372°F (-270 to 1300°C)
- Type C: 32 to 4200°F (0 to 2315°C)
- Type D: 32 to 4200°F (0 to 2315°C)
- Type F: 32 to 2449°F (0 to 1343°C)
- Type R: -58 to 3214°F (-50 to 1767°C)
- Type S: -58 to 3214°F (-50 to 1767°C)
- Type B: 32 to 3300°F (0 to 1816°C)
- RTD (DIN): -328 to 1472°F (-200 to 800°C)
- Process: -1999 to 9999 units

#### Calibration Accuracy

- Calibration accuracy and sensor conformity:  $\pm 0.1\%$  of span,  $\pm 1^\circ\text{C}$  at the calibrated ambient temperature and rated line voltage
  - Types R, S, B:  $\pm 0.2\%$
  - Type T below  $-50^\circ\text{C}$ :  $\pm 0.2\%$
- Calibration ambient temperature at  $77^\circ\text{F} \pm 5^\circ\text{F}$  ( $25^\circ\text{C} \pm 3^\circ\text{C}$ )
- Accuracy span:  $1000^\circ\text{F}$  ( $540^\circ\text{C}$ ) min.
- Temperature stability: Typical  $\pm 0.1^\circ\text{F}/^\circ\text{F}$  ( $\pm 0.1^\circ\text{C}/^\circ\text{C}$ ) rise in ambient max.

#### Configuration Diagnostics

- Indicates if modules present match the expected configuration settings

#### USB Device Port (Coming soon, consult factory for availability.)

- Version: USB 2.0 full-speed
- Connector: USB Mini Type B, 5 position
- Recognized as a mass storage device/serial communications
- Driver for Microsoft® Windows® 7 and Windows® 8

#### USB Host Port

- Total of 2 available
- Version: USB 2.0 hi-speed
- Connector: USB Type A, high-retention
- Flash drive must be FAT32 file system
- Max. current 0.5A/port

#### System Configuration Requirements

- D4T has 6 slots for flex modules (FM)
- EIA-232/485 Modbus® RTU flex module, if used, must occupy slot 6 location
- A maximum of two 10A SSR FM modules can be used in the F4T and each will require space for 2 slots. Valid in slots 1, 2, 4 or 5

#### Wiring Termination—Touch-Safe Terminals

- Right-angle and front-screw terminal blocks for input, output and power supply connections
- Input, output and power terminals: touch safe, removable, 12 to 30 AWG

### D4T Base Specifications

#### Line Voltage/Power

- High voltage option: 100 to 240VAC +10/-15%, 50/60Hz  $\pm 5\%$
- Low voltage option: 24 to 28VAC/VDC+10/-15%, 50/60Hz  $\pm 5\%$
- Power consumption: 23 W, 54VA

#### Environment

- NEMA 4X/IP65 front panel mount configuration only
- Operating temperature: 0 to 122°F (-18 to 50°C)
- Storage temperature: -40 to 185°F (-40 to 85°C)
- Relative humidity: 0 to 90%, non-condensing

#### User Interface

- 4.3 inch TFT PCAP color graphic touch screen
- LED backlife >50K hours
- 4 keys: Home, Main Menu, Back, Help

# Data Loggers

## D4T 1/4 DIN Data Logger

### Agency Approvals

- UL®/EN 61010 Listed, File E185611 QUXX
- UL® 508 Reviewed
- CSA CC.C#14, File 158031
- AMS 2750 E compliant: Analog input process values.  
Tip: Maximize field calibration accuracy and uniformity by using advanced F4T features such as Calibration Offset and Linearization Function Blocks. Refer to user manual for details.
- RoHS by design, China RoHS Level 2, W.E.E.E.
- CE
- Windows® Hardware Certification

### Inputs and Outputs

- Input sampling: 10Hz
- Output update: 10Hz

### Communications

- Ethernet Modbus® TCP
- EIA-232/485 Modbus® RTU
- Isolated communications

### Data Logging

- User selectable parameters: Up to a maximum of 128 active parameters depending on configuration
- Logging interval: Programmable increments between 0.1 seconds and 60 minutes if logging to internal memory. Logging directly to USB; 1.0 seconds to 60 minutes
- File types: .CSV for standard data logging or proprietary format for encrypted data log option
- Storage: 80MB internal memory or to USB memory stick
- File transfer: Internal memory to USB host port or to Ethernet Modbus® TCP
- Transfer options: On demand by user or user programmable based on when a new data log file record is available. Utilizes TFTP and Samba protocols
- Record: Date and time stamped

### Batch Processing with Bar Code Data Entry Via USB Scanner

- Compatible with many bar code types including Code 128, Code 39, Extended Code 39, Data Matrix, Interleaved 2 of 5, ISSN, SISAC, LOGMARS, QR, UCC/EAN-128 (GS1-128, UPC-A & E)
- Compatible with most USB scanner types such as Zebra DS4308, DS2208, LI2208 and LS2208
- USB port provides 500mA max. power supply for bar code scanner/base charging
- Display can show bar code fields up to a maximum length of 48 characters. Characters might wrap to 2 rows after 24 characters
- Program the bar code scanner to add an enter key (carriage return feed) at the end of each bar code data field sent to the F4T/D4T. Refer to USB scanner user manual.

### Trending

- 4 user programmable charts
- 6 pens available per chart
- View analog sensors and process values

### Real Time Clock with Battery Backup

- Accuracy (typical): +/-3ppm over -15 to 50°C
- Typical battery life: 10 years at 77°F (25°C)
- Field replaceable lithium battery

### Number of Function Blocks by Ordering Option

Function Block	Basic	Set 1	Set 2
Alarm	6	8	14
Compare	None	4	16
Counter	None	4	16
Linearization	4	4	8
Logic	None	12	24
Math	None	12	24
Process Value	4	4	8
Special Output Function (including compressor)	None	2	4
Timer	None	6	16
Variable	4	12	24

### Compare

- Greater than, less than, equal, not equal, greater than or equal, less than or equal

### Counters

- Counts up or down, loads predetermined value on load signal

### Linearization

- Interpolated or stepped

### Logic

- And, nand, or, nor, equal, not equal, latch, flip-flop

### Math

- Average, process scale, switch over, deviation scale, differential (subtract), ratio (divide), add, multiply, absolute difference, minimum, maximum, square root, sample and hold, pressure-to-altitude and dew point

### Process Value

- Sensor backup, average, crossover, wet bulb-dry bulb, switch over, differential (subtract), ratio (divide), add, multiply, absolute difference, minimum, maximum, square root, altitude, Vaisala® relative humidity and pressure-to-altitude

### Special Output Function

- Compressor control (cool and/or dehumidify with single compressor), motorized valve, sequencer

### Timers

- On pulse, delay, one shot or retentive

### Variable

- User value for digital or analog variable

# Data Loggers

## D4T 1/4 DIN Data Logger

### Panel Mount Dimensions

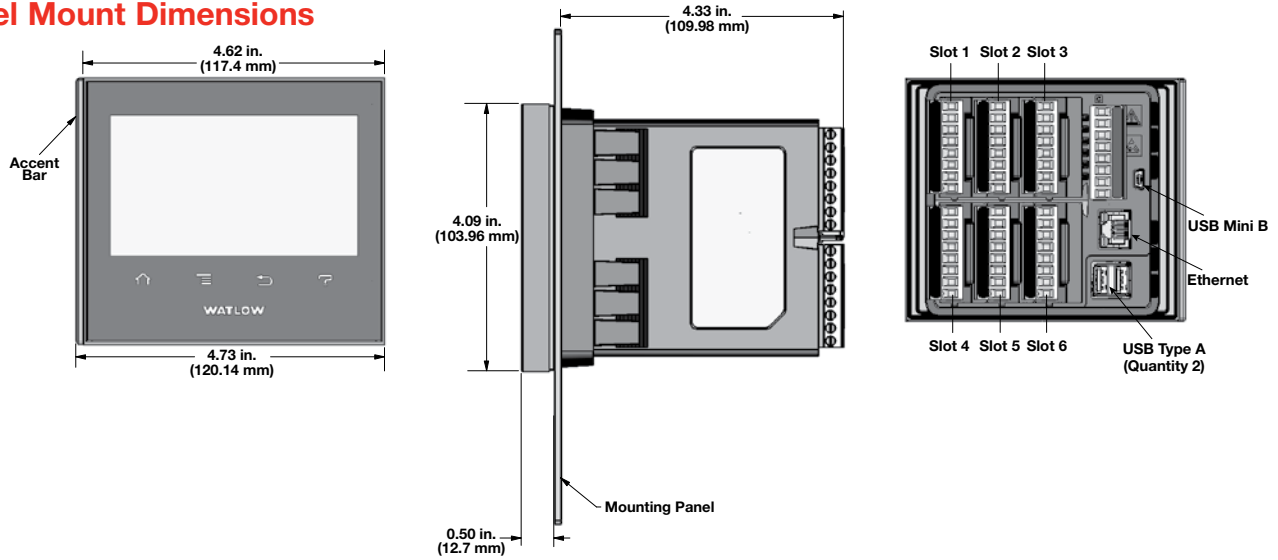

### Flush Mount Dimensions

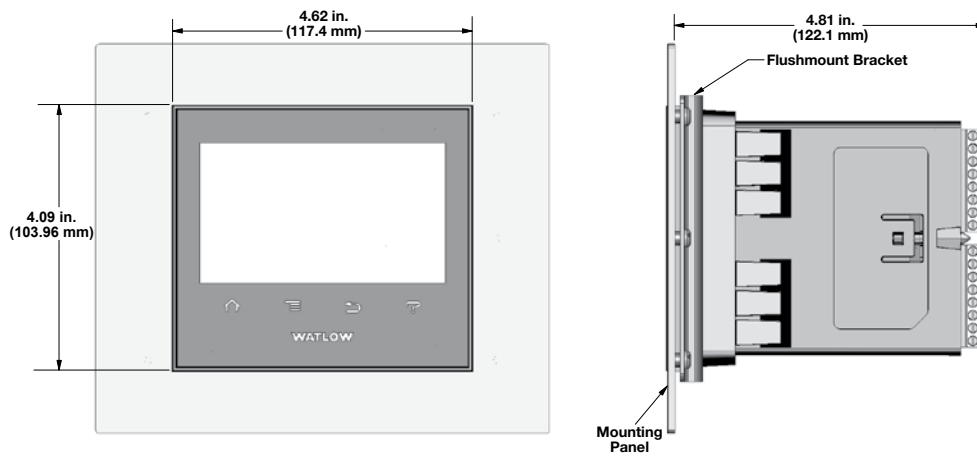

# Data Loggers

## D4T 1/4 DIN Data Logger



### Ordering Information

Base includes: 4.3 inch color graphical touch screen, standard bus communications, Ethernet Modbus<sup>®</sup> TCP and SCPI protocol.

#### Part Number

① ②	③	④	⑤	⑥	⑦	⑧ ⑨	⑩ ⑪	⑫	⑬ ⑭	⑮
Model	Base Type	Appl. Type	Data Logging & Trend Charts	Pwr. Sup. Voltage, Conn. Style, Watlow Logo Screenprint	Function Blocks	Future Options	Doc., Accent Bar, Replacement Conn. & Custom	Add'l Options	Nbr. Logging Channels & Input Hardware Types	Nbr. of Aux./Alarm Outputs, Digital Inputs & Hardware
D4	T					AA		5		

③ Base Type	
T =	Touch screen

④ Application Type	
1 =	Standard

⑤ Data Logging and Trend Charts	
J =	Data logging
K =	Data logging with encrypted files
L =	Data logging with graphical trend charts
M =	Data logging with encrypted files, graphical trend charts and batch processing with bar code data entry

⑥ Power Supply Voltage, Connector Style, Watlow Logo Screenprint			
	Power Supply	Power Supply Connector	Watlow Logo
1 =	100 to 240VAC	Right angle (standard)	Yes
2 =	100 to 240VAC	Right angle (standard)	No
3 =	100 to 240VAC	Front screw	Yes
4 =	100 to 240VAC	Front screw	No
5 =	24 to 28VAC or VDC	Right angle (standard)	Yes
6 =	24 to 28VAC or VDC	Right angle (standard)	No
7 =	24 to 28VAC or VDC	Front screw	Yes
8 =	24 to 28VAC or VDC	Front screw	No

⑦ Function Blocks			
	Basic Set	Set 1	Set 2
A =	X		
B =		X	
C =			X

⑧ ⑨ Future Options	
AA =	Future Options

⑩ ⑪ Documentation, Accent Bar, Replacement Connectors & Custom					
	Documentation DVD/QSG	Decorated Brush Aluminum Accent Bar			
		Gray	Blue	Red	None
1A =	Yes	X			
1B =	Yes		X		
1C =	Yes			X	
1D =	Yes				X
1E =	No	X			
1F =	No		X		
1G =	No			X	
1H =	No				X
1J =	Replacement connectors only - for the model number entered				
XX =	Contact factory, other custom-firmware, preset parameters, locked code, logo				

⑫ Additional Options	
5 =	None

#### ⑬ ⑭ Number of Logging Channels & Input Hardware Types

##### Universal Input(s) (T/C, RTD 2- or 3-wire, 0-10VDC, 0-20mA)

- U1 = 1 channel
- U2 = 2 channels
- U3 = 3 channels
- U4 = 4 channels
- U5 = 5 channels
- U6 = 6 channels

##### Thermistor Input(s)

- T1 = 1 channel
- T2 = 2 channels
- T3 = 3 channels
- T4 = 4 channels
- T5 = 5 channels
- T6 = 6 channels

##### Universal Input(s) (T/C, RTD 2-wire, 0-10VDC, 0-20mA)

- 04 = 4 channels
- 08 = 8 channels
- 12 = 12 channels
- 16 = 16 channels
- 20 = 20 channels
- 24 = 24 channels

##### Thermistor Input(s)

- TA = 4 channels
- TB = 8 channels
- TC = 12 channels
- TD = 16 channels
- TE = 20 channels
- TF = 24 channels

##### Custom

XX = Different channel quantity and combination options. Contact factory for assistance.

#### ⑮ Number of Auxiliary/Alarm Outputs, Digital Inputs & Hardware

##### Options below are not available with 6 or 24 channel input models

A = None

##### Single Output

- C = 1 switched dc/open collector
- E = 1 mechanical relay 5A, Form C output
- F = 1 universal process/retransmit

##### Multiple Digital Inputs/Outputs

- D = 6 digital I/O
- P = 3 universal process/retransmit outputs
- B = 3 mechanical relay 5A, 2 Form C and 1 Form A (Form A shares a common with 1 Form C)
- J = 4 mechanical relay 5A, Form A
- K = 2 SSRs Form A, 0.5A
- T\* = 2 SSRs at 10A
- L = 2 SSRs at 2A each, SSRs grouped in 2 pairs with each pair sharing a common

##### Communications

M = Modbus<sup>®</sup> RTU 232/485

##### Custom

X = Different output quantity and combination options. Contact factory for assistance.

\*Option "T" not available with digit 13 & 14, options U5, U6, T5, T6, 20, 24, TE and TF.

# Data Loggers

## F4T With INTUITION®

The F4T with INTUITION® temperature process controller offers a wide range of field removable I/O modules for maximum design flexibility. Configurations can be custom tailored to meet the scaling needs of a tremendous range of equipment and applications while providing exactly the hardware types required for compatibility. The F4T controller also features a 4.3 inch, color, graphical touch panel. Combining power, flexibility and functionality, this new controller offers unmatched versatility, and its best-in-class ease of use could very well make user manuals a thing of the past.

### Features and Benefits

#### 4.3-inch, color touch panel with high-resolution, graphical user-interface

- Shortens learning curve and reduces operator errors
- Allows channels, profiles, alarms, inputs and outputs to be personalized with user defined names

#### Temperature PID, data logger, trend chart, over/under-temperature limit, power switching, math, logic, timers and counters combined into an integrated system

- Lowers ownership costs
- Eliminates the need for separate discrete components
- Reduces complexity
- Simplifies design, ordering and installation
- Saves money

#### Robust algorithms for temperature, cascade, altitude, humidity and compressor

- Improves process control
- Offers one to four channels of control
- Provides multiple PID sets
- Enables TRU-TUNE®+ adaptive control algorithm
- Offers 40 ramp and soak profiles with real-time clock and battery backup

#### COMPOSER® graphical configuration PC software

- Speeds up and simplifies commissioning
- Archives and documents controller setup
- Connects with controller easily via Ethernet

#### Many communications options available including Ethernet Modbus® TCP and SCPI and EIA-232/485 Modbus® RTU

- Offers two USB host ports and one device port
- Simplifies file transfers
- Connects easily



#### Batch Processing with Bar Code Data Entry

- Easily collects and manages data records
- Inputs information from bar code scan for fast and easy data entry
- Offers foolproof processing via smart profile to part linkage
- Provides data security through password and data log encrypted file options
- Improves manufacturing robustness via reminder screens ensuring all data is entered during processing
- Helps ensure compliance with growing regulations and minimizes warranty exposure
- Eliminates part processing skips or walk arounds due to improved quality control
- Produces formatted data record report for easy receipt or record management uses

#### Modular design

- Adapts quickly to evolving requirements
- Offers numerous types of field pluggable modules for maximum flexibility and easiest compatibility
- Features scalable and modular firmware functions
- Delivers scalable input/output quantities from 1 to 36

#### Agency certifications include UL®, FM, CE, RoHS, W.E.E.E., NEMA 4X/IP65

- Ensures high quality and reliability
- Verifies performance in installations worldwide

**For detailed product and ordering information, see the full F4T product section located on pages 189 through 199.**



# Data Loggers

## EZ-ZONE® RM System with Access Module

The EZ-ZONE® RM controller simplifies thermal system management. The EZ-ZONE RM controller family is comprised of six module types: an integrated on-off or PID control, monitoring and over/under temperature limit module, a high-density on-off or PID control module, a high-density limit only module, an input/output (I/O) expansion module, a high-density monitor/scanner module and a data logging and field communications access module. A system is configured by connecting any combination of module types to address specific application needs. The EZ-ZONE RM is extremely flexible and scalable allowing mixing and matching of I/O to configure one to 152 control loops and up to 256 monitor points.

### Optional integrated controller functions can be combined or ordered in different quantities:

- PID control loops
- Over/under temperature limit control loops
- 10 and 15 ampere power output/heater driver options
- On-board data logging
- Current measurement input
- Sequencer start up and control function
- Programmable timer and counter functions
- Programmable math and logic options
- Multiple communication protocol options
- Mobile configuration with removable secure digital (SD) flash card

### Benefits of using an integrated controller solution:

- Reduces wiring time and termination complexity compared with connecting multiple discrete products
- Improves system reliability
- Reduces termination and installation cost
- Eliminates compatibility issues often encountered with using various discrete components and brands
- Reduces troubleshooting time and downtime costs because the system can specifically identify any problems with a sensor, controller, solid state relay (SSR) power output or heater load
- Complete thermal solution saves engineering time and labor costs while shortening project schedules

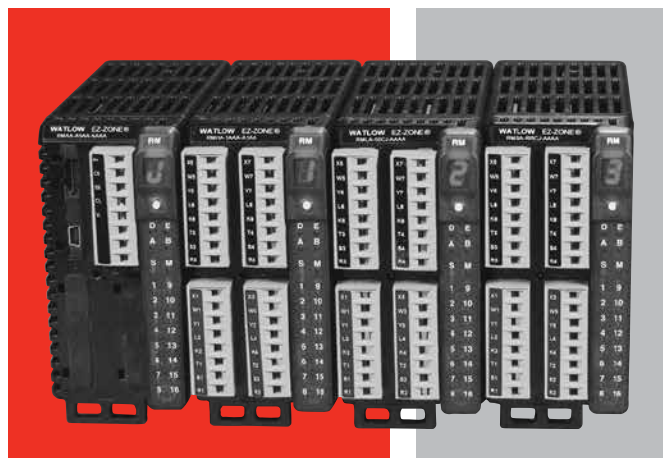

## Features and Benefits

### Multiple inputs; from one to 152 PID loops of control or monitor up to 256 analog inputs

- Mix and match I/O to fit any application; from one input with two outputs to 152 analog inputs with 152 outputs, or monitor up to as many as 256 analog inputs all in one system
- Reduces cost because only required loops are purchased
- Allows a common controller platform across many design applications as both loops and outputs can be ordered in single increments

### Advanced PID control algorithm

- Offers TRU-TUNE®+ adaptive control to provide tighter control for demanding applications
- Enables auto-tune for fast, efficient start-up

### Communication capabilities

- Provides a range of protocol options including universal serial bus (USB) device port, Modbus® RTU, EtherNet/IP™, Modbus® TCP, DeviceNet™ and PROFIBUS

### USB Port

- Provides data log retrieval

### SPLIT-RAIL control

- Enables modules mounted in separate high-voltage and low-voltage cabinets to function as an integrated system
- Minimizes the length and cost of wire runs and improves system reliability by locating inputs closer to sensors and outputs closer to loads

**For detailed product and ordering information, see the full EZ-ZONE RM product section located on pages 200 through 219.**

# Data Loggers

## RMA PLUS Remote Access Module

Watlow's new RMA PLUS remote access module supports Watlow's powerful EZ-ZONE® RM temperature controller family by communicating with and providing access to all EZ-ZONE RM modules in a system.

EZ-ZONE RMA users have had to spend more time than desired to connect their entire system. Now the RMA PLUS offers standard state-of-the-art connectivity from the device to the entire system. Real-time communication is possible via a built-in Ethernet switch or USB. Users can also connect to third-party and legacy devices because the RMA PLUS acts as a gateway between Modbus® TCP and Modbus® RTU.

The device comes standard with a built-in managed Ethernet switch with two Ethernet jacks. Up to three Modbus® TCP sessions, three Watbus over Ethernet sessions and one Watbus over USB session is available in a single device. Users can also log up to 16 gigabytes of data standard or upgrade to a maximum of 32 gigabytes. Configuration and data logs are available as Windows® files so they can be easily accessed. In addition, discovery and transfer speeds have gone from minutes with the legacy EZ-ZONE RMA to just seconds with the RMA PLUS.

Because the RMA PLUS is an essential component of the EZ-ZONE RM family, users receive all the benefits and support of working with Watlow®.

To view a comparison between the legacy EZ-ZONE RM Access Module and the new RMA Plus go to [www.watlow.com/rmaplus](http://www.watlow.com/rmaplus).



### Features and Benefits

#### Plug and play access to EZ-ZONE RM family

- Integrates easily into existing systems

#### Built-in Ethernet switch

- Eliminates the need to provide a switch for small systems
- Offers port mirroring for troubleshooting
- Protects from broadcast and multicast storms

#### Integrated USB connection

- Provides easy connection from PC with no converter
- Ensures real-time communication from software packages

#### Modbus® TCP and Modbus® RTU

- Allows users to build tables based on individual needs
- Connects to third-party and legacy devices

#### Data logging

- Offers users the opportunity to log any data point in the system

**For detailed product and ordering information, see the full EZ-ZONE RM product section located on [pages 200 through 219](#).**

# Data Loggers

## SpecView HMI Software

SpecView software is an easy-to-use Human Machine Interface (HMI) to Watlow controllers, including the F4T with INTUITION process controller and EZ-ZONE controllers as well as third-party products. Watlow's single point of support for hardware, software and application needs ensures knowledgeable and expedient responses to questions or concerns.

This competitively priced package includes field-proven features, many suggested by loyal users. Built-in support and auto-detect for Watlow controllers make setup quick and simple. SpecView is ideal for industrial applications with support for barcode readers and touch-screen operation.

To try before purchasing, download SpecView from the Watlow website and run in the time-limited demo mode.

### Features and Benefits

#### Built-in support and auto-detect for controllers

- Saves set-up time
- Eliminates the need to learn communications protocols
- Integrates devices from multiple vendors

#### Watlow EZ-ZONE standard bus communications protocol

- Communicates with any EZ-ZONE product without requiring purchase of a communications option

#### Highly configurable trending/graphing

- Simplifies monitoring and troubleshooting processes and machines
- Provides a permanent, unalterable record of results

#### Flexible data logging and report generator

- Helps users comply with regulatory requirements including AMS 2750D NADCAP
- Reduces labor and increases accuracy by automating data collection
- Simplifies record keeping by consolidating measurements, operator comments and other information into Excel® - compatible report formats
- Allows data to be grouped in user-defined batches
- Records operator actions

#### Easy-to-build, customizable screens

- Allows creation of application-specific screens, which can automate tasks, decrease training time and simplify monitoring and operation
- Highlights specific parameter values with user-set color dynamics and provides bar graphs for "at-a-glance" monitoring
- Limits access with passwords if desired



#### Easy-to-use recipe manager

- Saves snapshot of current parameter settings
- Eliminates operator error when setting machine parameters
- Reviews and edits complex programmer profiles

#### Historical replay option

- Helps troubleshoot processes by allowing review of recorded data

#### Remote access option

- Allows multiple, identical operator stations for convenient access
- Reduces downtime and increases utilization with monitoring and access over LAN, modem or Internet

### System Requirements

#### Compatible Operating Systems:

- Windows® 10, 8.1, 8, 7, Vista, Server 2003 and XP

#### Minimum System:

- Pentium® processor or equivalent AMD
- 1GB RAM (2GB or more recommended)
- 100MB hard disk space to install SpecView
- Additional disk space for data logging
- Instrument connection: serial port or Ethernet
- USB port for the key

#### Ideal System:

- Intel® Core™ i5 2.6Ghz processor or AMD equivalent
- 2GB RAM
- 500GB hard disk plus enough space for data logging

# Data Loggers

## SpecView HMI Software

### Supported Controllers and Protocols

Controller	Controller's Communication Protocol		
	Standard Bus	Modbus® RTU	Modbus® TCP
F4T with INTUITION	N/A	✓	✓
EZ-ZONE RM, PM and ST	✓	✓ ①	✓ ①
SERIES F4 Ramping	N/A	✓	N/A
SERIES 96, 97, SD	N/A	✓	N/A
POWER SERIES	N/A	✓	N/A
MICRODIN	N/A	✓	N/A
SERIES 986, 987, 988, 989	N/A	✓	N/A
CLS200 (standard or ramp/soak)	N/A	✓	N/A
MLS300 (standard or ramp/soak)	N/A	✓	N/A

① Modbus® support for basic operation parameters is included. Automatic detection of EZ-ZONE instruments is not available via Modbus® so configurations must be set up manually. EZ-ZONE ST controllers versions 1 to 3 are supported via Modbus® with a RUI Gateway only.

### Application Examples

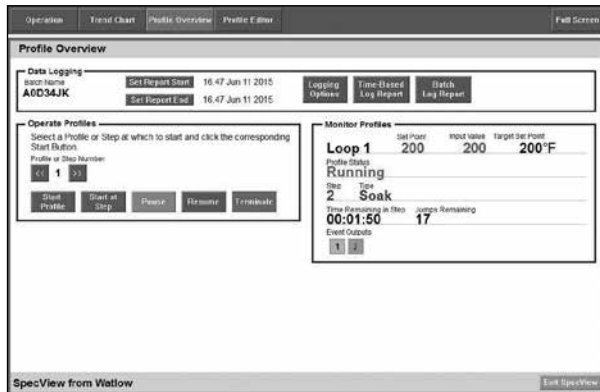

Track and report batch-specific processing data.

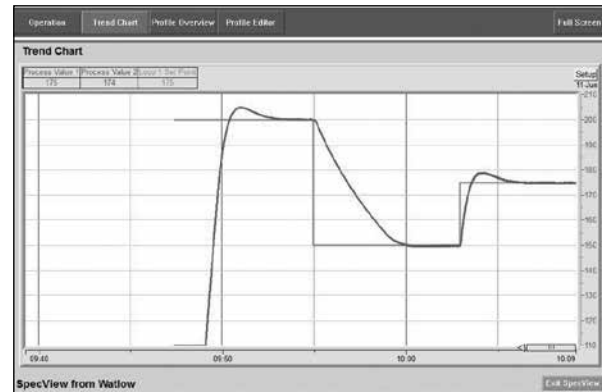

Graph and log process data. Replay data that may have been missed while a user was away. For playback of data older than four hours get the historical replay option.

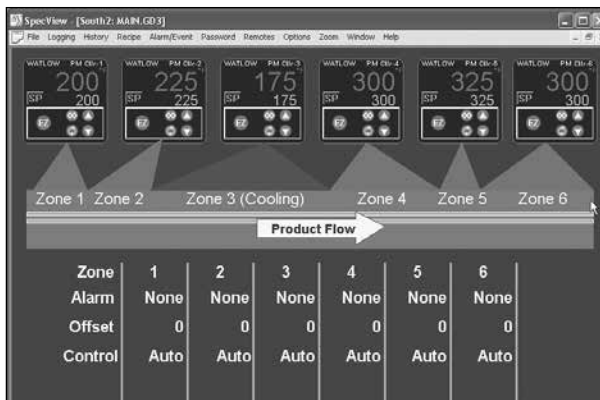

Create application-specific screens that depict process data so users can relate.

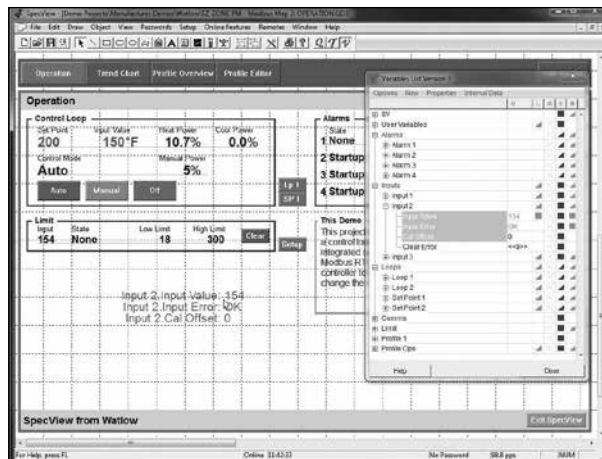

Make screens with drag-and-drop ease.

# Data Loggers

## SpecView HMI Software

### Ordering Information - Standard

#### Part Number

① ②	③	④	⑤	⑥	⑦	⑧ ⑨	⑩	⑪	⑫	⑬
SV	Version S	Ports	Historical Replay & Strategy Cont.	DDE and OPC	ActiveX Container	Remote Users	Special Watlow Drivers	Third Party Drivers	Update Plan	0

③ Version	
S =	Standard
④ Ports	
S =	Single
M =	Multiple
⑤ Historical Replay and Strategy Controller	
0 =	None
H =	Historical replay
S =	Strategy controller
B =	Both
⑥ DDE and OPC	
0 =	None
D =	DDE
C =	OPC client
B =	Both
⑦ ActiveX Container	
0 =	None
A =	ActiveX container

⑧ ⑨ Remote Users	
00 =	None
XX =	Number of simultaneous remote users (01 to 99)
⑩ Special Watlow Drivers	
0 =	None
1 =	SERIES F4 programmer
⑪ Third Party Drivers	
0 =	None
1 =	Allen-Bradley® DF1
<b>Note:</b> Special drivers for other third-party products (Honeywell, Eurotherm, Mitsubishi, Yokogawa and Marathon) are available directly from SpecView.	
⑫ Update Plan	
0 =	One year of free updates
5 =	Five additional years of updates (six years total)

### Ordering Information - Mini

#### Part Number

① ②	③	④	⑤	⑥	⑦	⑧ ⑨	⑩	⑪	⑫	⑬
SV	Version M	Ports	Historical Replay & Strategy Cont.	DDE and OPC	ActiveX Container	Remote Users	Special Watlow Drivers	Third Party Drivers	Update Plan	0

③ Version	
M =	Mini (limited to two instrument views)
<b>Note:</b> The mini version is limited to two instrument views and may not be appropriate for use with some devices such as profiling and multi-loop controllers where a single device appears as multiple instruments in SpecView.	
④ Ports	
S =	Single
M =	Multiple
⑤ Historical Replay and Strategy Controller	
H =	Historical replay
B =	Historical replay and strategy controller
⑥ DDE and OPC	
0 =	None
D =	DDE
C =	OPC client
B =	Both

⑦ ActiveX Container	
0 =	None
A =	ActiveX container
⑧ ⑨ Remote Users	
00 =	None
XX =	Number of simultaneous remote users (01 to 99)
⑩ Special Watlow Drivers	
0 =	None
1 =	SERIES F4 programmer
⑪ Third Party Drivers	
0 =	None
1 =	Allen-Bradley® DF1
<b>Note:</b> Special drivers for other third-party products (Honeywell, Eurotherm, Mitsubishi, Yokogawa and Marathon) are available directly from SpecView.	
⑫ Update Plan	
0 =	One year of free updates
5 =	Five additional years of updates (six years total)

# Data Loggers

## SpecView HMI Software

### Ordering Information - Upgrade

#### Part Number

① ②	③	④	⑤	⑥	⑦	⑧ ⑨	⑩	⑪	⑫	⑬
	Version	Ports	Historical Replay & Strategy Cont.	DDE and OPC	ActiveX Container	Remote Users	Special Watlow Drivers	Third Party Drivers	Extend or Restart Update Plan	
SV				-			-			0

③ Version	
U =	No version change; upgrade options only
N =	Upgrade mini to standard

④ Ports	
0 =	No upgrade
M =	Multiple

⑤ Historical Replay and Strategy Controller	
0 =	No upgrade
H =	Historical replay (already included with SpecView Mini)
S =	Strategy controller
B =	Both (do not order this option with SpecView Mini)

⑥ DDE and OPC	
0 =	No upgrade
D =	DDE
C =	OPC client
B =	Both

**Note:** Your upgrade order must be accompanied by the Step 1 code from the Upgrade screen in SpecView. Use the upgrade order form available at [www.watlow.com](http://www.watlow.com) or upon request from Watlow or your authorized distributor.

⑦ ActiveX Container	
0 =	No upgrade
A =	ActiveX container

⑧ ⑨ Remote Users	
00 =	No upgrade
XX =	Number of simultaneous remote users (01 to 99)

⑩ Special Watlow Drivers	
0 =	No upgrade
1 =	SERIES F4 programmer

⑪ Third Party Drivers	
0 =	No upgrade
1 =	Allen-Bradley® DF1
<b>Note:</b> Special drivers for other third-party products (Honeywell, Eurotherm, Mitsubishi, Yokogawa and Marathon) are available directly from SpecView.	

⑫ Extend or Restart Update Plan	
0 =	No additional updates
2 =	Extend update plan by two years. <b>Note:</b> Valid only <b>prior</b> to expiration of the update plan.
5 =	Extend update plan by five years. <b>Note:</b> Valid only <b>prior</b> to expiration of the update plan.
U =	Start a new two-year update plan. <b>Note:</b> Select this option to update SpecView after its update plan has expired.
A =	Start a new two-year update plan. <b>Note:</b> Valid one time only when upgrading from version 2.5 to version 3.

## SpecView HMI Software

### How to Choose the Correct SpecView Options

Order this option...	If you want to...
<b>Mini Version</b>	Operate a system with data from one or two simple instruments. This option includes historical replay and allows up to two instruments. Note that in some cases, devices such as profiling and multi-loop controllers are represented by more than one instrument, the mini version may not be appropriate.
<b>Standard Version</b>	Be free to expand configurations beyond the two instrument limit of the mini version.
<b>Single Port</b>	Communicate with instruments on only one serial communications port or only via Ethernet only.
<b>Multiple Port</b>	Communicate with instruments on more than one serial communications port and via Ethernet.
<b>Historical Replay</b>	Replay logged data on screens in trends, bar graphs and numeric fields. Without the option, replay is limited to the last four hours of data.
<b>Strategy Controller</b>	Configure SpecView to respond automatically to events such as specific parameter values with actions such as printing the screen, starting logging or download a recipe. Events can also be time or calendar based. Without the strategy controller option there is a two event limit.
<b>DDE</b>	Integrate SpecView with other Windows® programs.
<b>OPC Client</b>	Connect SpecView to instruments via a third-party OPC server.
<b>ActiveX Container</b>	Integrate third-party or customer-written ActiveX controls into SpecView.
<b>Remote Users</b>	Monitor instruments from multiple computers simultaneously. Order the number of remote users corresponding to the maximum number of additional computers needed to connect simultaneously.
<b>SERIES F4 Programmer Driver</b>	Use the computer to manage profiles: program profiles in the computer, save profiles on the computer, or download profiles that are saved on the computer to the SERIES F4.
<b>Allen-Bradley® DF1 Driver</b>	Connect to Allen-Bradley® PLCs (process logic controllers) that support the DF1 protocol
<b>Update Plan</b>	SpecView includes one year of free updates with an option for five additional years. The update period may be extended or restarted with field upgrade options.

# Data Loggers

## Silver Series EM

The Silver Series EM is a rugged, touch-screen operator interface terminal (OIT). Available in three sizes (4.3, 7 and 10 inch diagonal display sizes), the OIT's feature serial and Ethernet communications with multiple controllers, email messaging, universal serial bus (USB host), data logging, flexible password security and multiple languages. The small bezel size and two-inch depth make mounting in tight spots easy.

The Silver Series EM programming software, EZwarePlus, is easy to use and features a large variety of built-in screen objects that makes it powerful. When creating screens, the user can call upon extensive graphics libraries, import custom graphics and add numeric displays, entry fields, analog meters, bar graphs and trend graphs with just a few mouse clicks. Screen objects are highly customizable, and the user can create libraries of their own objects for repeat use. The online simulator, Ethernet and USB support make testing and downloading fast. The EZwarePlus screen editor is part of the EZwarePlus software suite and is available as a FREE download on [www.watlow.com](http://www.watlow.com).

The Silver Series EM OIT paired with Watlow controllers is the perfect solution for your industrial process or machine control application.

### Features and Benefits

#### Bright, color, high resolution, graphic, touch screen, thin film transistor (TFT) display

- Maximizes display space in the OIT footprint
- Allows application specific interface design
- Allows viewing from a distance and at an angle
- Highlights important process information with color and animation

#### User selectable portrait or landscape operation

- Fits in tight spots



#### Ethernet, serial and USB host ports

- Allows options for connecting to controllers
- Provides options for downloading projects
- Expands memory for additional recipe and data log storage
- Supports barcode readers, keyboard, mouse and printers
- Supports monitoring from a personal computer (PC) with free virtual network computing (VNC) client software

#### Support for over 100 protocols, up to three simultaneously plus multiple protocols over Ethernet

- Connects to a wide range of industrial controllers and devices
- Integrates a variety of devices to simplify complex operation tasks

#### Data logging, display and trending

- Helps operators monitor processes
- Reduces labor and increases accuracy by automating time-stamped data collection
- Stores captured data for future retrieval in multiple files
- Saves time by exporting data to Excel®-compatible comma separated value (.csv) files
- Improves process understanding by allowing live and historical data to be viewed on the OIT

**For detailed product and ordering information, see the full Silver Series EM product section located on **pages 335 through 340.****